Universal Leak Tester

User Guide



ULT-M100



Table of Contents

1. Product Outline	2
2. Safety Notice	
2-1. Caution for handling of High Voltage Parts	3
2-2. Caution for Use of Equipment	3
3. Specification and Components	
3-1. Product Specification	4
3-2. Components	5
4. Tester Features and Test preparation	
4-1. Tester Features	8
4-2. Test Preparation	9
5. Test Procedure	
5-1. Coolant Discharge	13
5-2. Coolant Line Leak Test	16
5-3. Self Test [Coolant Fitting (IN/OUT)]	18
5-4. Battery Pack Leak Test	20
5-5. Self Test [Battery Pack Air Injection Adapter]	23
6. Switching Method of Spare Parts	
6-1. Air Injection Adapter/Pressure Sensor Module O-Ring (Battery Pack)	24
6-2. Coolant Fitting Flat O-Ring (IN/OUT)	24
6-3. Coolant Fitting R-Pin (IN/OUT)	24
7. Product Warranty / Certification	25

1. Product Outline

The ULT-M100 Universal Leak Tester (the “testers”) is a precision digital control test equipment to check the required proper sealing(airtightness) status of H.V battery pack safety maintenance as correctly that are measured for micro leakage pressure during a certain minute after applying proper pressure at the battery pack coolant line and battery pack case inside.

- Test Range

Sealing(airtightness) maintenance check for H.V Battery Pack Coolant Line and H.V Battery Pack Case Inside.

- Use Purpose

The ULT-M100 Universal Leak Tester is focused on correct diagnosis of complete Battery pack case sealing through appropriate internal air pressure maintenance of the H.V Battery pack case because H.V Battery pack which is installed Electric Vehicle should be protected from any kind of Water /Moisture or Foreign material on the outside of Battery pack case.

Therefore H.V Battery pack sealing test is requested as an essential process when conduct the Battery pack case re-assembly or replacement from any kind of repair or test work for the H.V Battery pack/ Module/ Cells after open the pack case in a service field.

2. Safety Notice

2-1. Caution for handling of High Voltage Parts

- Be sure to shut off the High voltage by removing the safety plug before performing inspection or repairing the High voltage system.
- Do not keep any metal objects(watch, ring etc.) while working on the High voltage system, which can cause serious accidents like electric shock.
- Before beginning work on the High voltage system, the worker should wear personal protective insulation equipment to prevent safety accidents.
- Never allow workers who don't wear personal protective insulation equipment to touch the High voltage system.

2-2. Caution for Use of Equipment

- Clear surface matter of all parts of ULT-M100 before/after use of the equipment and maintain the clean status.
- Read, understand and follow all instructions in this manual before using the ULT-M100 "Universal Leak Tester".
- Please familiarize Vehicle management safety instruction before use of ULT-M100.
- Use ULT-M100 in a good ventilation environment only and always wear protective equipment (protective goggles & glove) when using the equipment
- When equipment has damage or break by the exterior impact, be sure to stop the usage of ULT-M100 immediately, and should repair via manufacturer if necessary. (Abnormal repair can be caused for equipment breakdown)
- Do not expose the equipment to the Rain or Snow.
- Do not use as other usages except diagnosis purpose for H.V battery pack.
- Do not leave alone on the vehicle installation status.
- The use out of operating temperature(0 ~ 40°C) could cause the failure of equipment.

3. Product Specification & Components

3-1. Product Specification







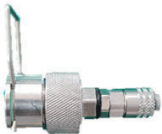

Item		Specification	
Display		LCD : 240*128(DOT) / BLU	
Condition Mark LED		4 Color LED	
Radio Communication		Bluetooth V5.0(BLE)	
Alarm		Buzzer (75db / 2600Hz)	
Pressure Sensor	Coolant Line	Injection/ Judgement	Measurement Range : 0 ~ 4bar Accuracy : $\pm 0.25\%$ FS
	Battery Pack	Injection	Measurement Range : -0.5 ~ +0.5bar Accuracy : $\pm 0.25\%$ FS
		Measurement	Measurement Range : 0 ~ 5Kpa Accuracy : $\pm 0.25\%$ FS
Power Adapter	Input		100-240V $\pm 10\%$, 50/60 Hz, 2.0A
	Output		12V d.c., 10A
Max. Consumption Power		MAX. 60W	
Operating Temperature		0°C ~ 40°C	
Use environment		Indoor use	
Use Altitude		Up to 2000m	
Min. Humidity Condition		Maximum relative humidity 80% for temperature up to 31°C decreasing linearly to 50% relative humidity at 40°C	
Over Voltage Category		CATII (Adapter) / CATI (Unit)	
Applicable RATED POLLUTION degree		“Pollution Degree 2”	
Certification		KC / CE / FCC	

3. Specification and Components

3-2. Components

Name	Part Number	Image	Q'ty	Remarks
Main Case [Main Test Unit]	G7XHDNN002		1EA	
Accessory Case [Accessory]	G7XHDNN003		1EA	
Tester Body	G7XHDNN005		1EA	
Power Adapter	G7XHDNN006		1EA	
Air Injection Adapter [for Battery Pack]	G7XHDNN007		1EA	
Pressure Sensor Module [for Battery Pack]	G7XHDNN008		1EA	
Air Injection Adapter [for Coolant Line]	G7XHDNN009		1EA	

3. Specification and Components

Name	Part Number	Image	Q'ty	Remarks
Coolant Line Fitting [In]	G7XHDNN010		1EA	Coolant Line Inlet
Coolant Line Fitting [Out]	G7XHDNN011		1EA	Coolant Line Outlet
Coolant Discharge Hose	G7XHDNN012		1EA	
Connection Adapter [for Coolant discharge]	G7XHDNN013		1EA	
Self Test Adapter	G7XHDNN014		1EA	Self test for Coolant line leak test
Sealing Connector [Main] [E001]	G7XHDNN015		1EA	
Sealing Connector [Main/New] [E002]	G7XHDNN016		1EA	
Sealing Connector [Heating] [E003]	G7XHDNN017		1EA	

3. Specification and Components

Name	Part Number	Image	Q'ty	Remarks
Sealing Connector [Communication] [E004]	G7XHDNN018		1EA	
Sealing Connector [Quick Charge] [E005]	G7XHDNN019		1EA	
Sealing Connector [FR DC] [E006]	G7XHDNN020		1EA	
Sealing Connector [RR DC] [E007]	G7XHDNN021		1EA	
Sealing Connector [ICCU DC] [E008]	G7XHDNN022		1EA	
Spare Parts	G7XHDNN023		1 SET	O-ring : 6EA Flat O-ring : 4EA R Pin : 2EA
User Guide	G7XHDNN004		1EA	

4. Tester Features and Test preparation

4-1. Tester Features

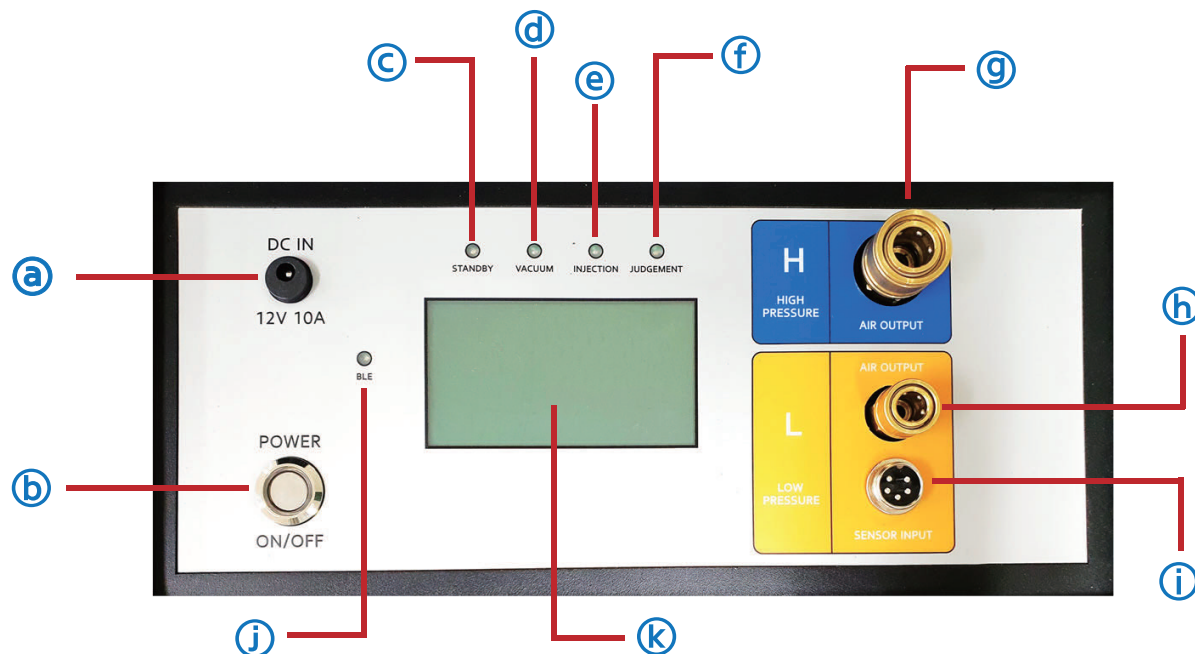

Item	Feature	Description
a	DC IN	Body Power Jack (12V 10A)
b	POWER	Power Switch (ON/OFF)
c	STANDBY LED	Ready for Tester operation
d	VACUUM LED	Air-pump operation (Vacuum pressure)
e	INJECTION LED	Air-pump operation (Constant pressure)
f	JUDGEMENT LED	Judgement
g	HIGH PRESSURE AIR OUTPUT	Coolant Line Air Output
h	LOW PRESSURE AIR OUTPUT	Battery Pack Air Output
i	LOW PRESSURE SENSOR INPUT	Battery Pack Pressure Measurement
j	BLE LED	Bluetooth connection status display
k	LCD	Operation status display

4. Tester Features and Test preparation

4-2. Test Preparation [Body Power Supply]

1. Connect Power Jack to the tester body.

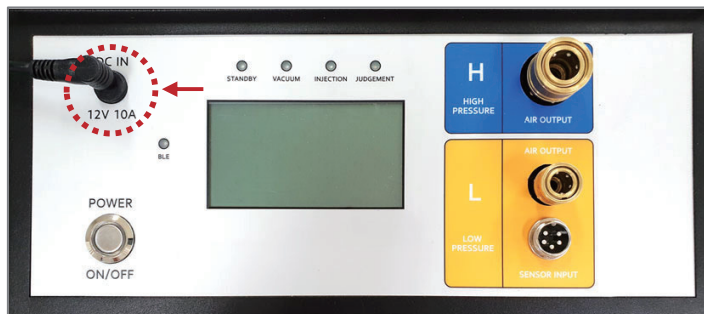

2. Push the Power Switch (ON).

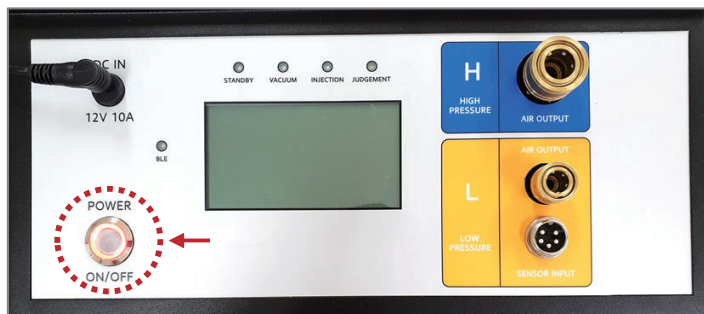

3. Power supply status.

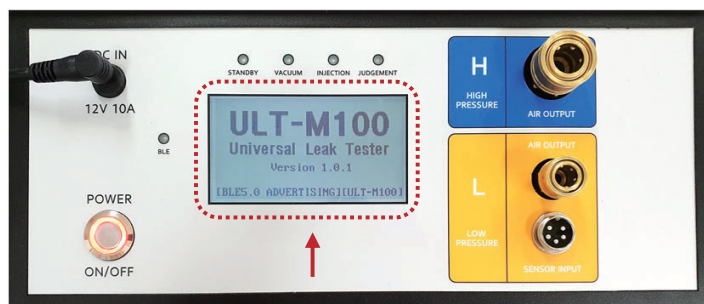

4. Tester Features and Test preparation

4-2. Test Preparation [Vehicle Selection]

1. Select the “Tool Box”.



[GDS Smart]

2. Select the “S/W Management”.

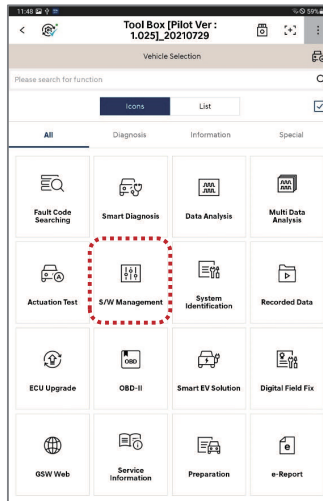

[GDS Smart]

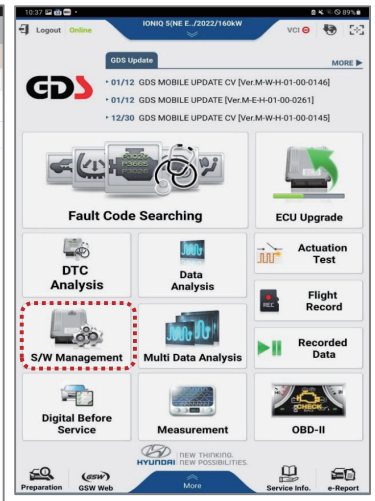

[GDS]

2. Select the “Test Vehicle”.

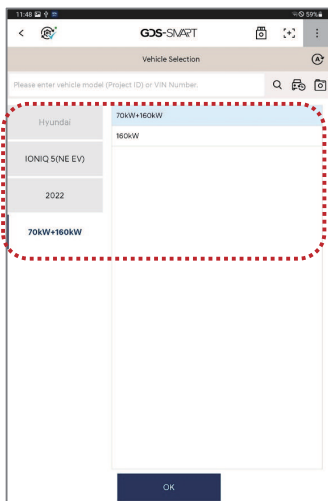

3. Select the “High Voltage Battery Pack & Coolant Line Leak Test”.

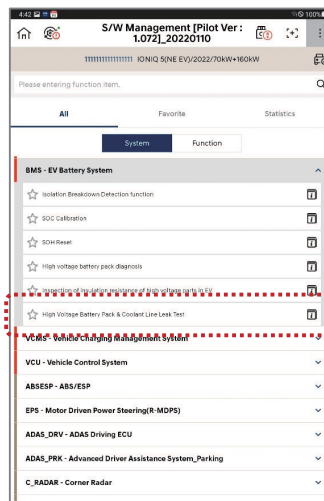

4. Press the “Run” button on the bottom side.

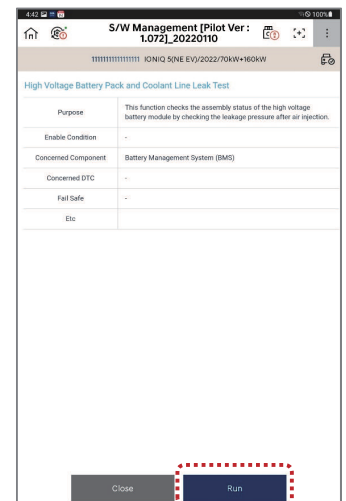

4. Tester Features and Test preparation

4-2. Test Preparation [QR Code Scan]

1. Scan the H.V Battery Pack QR Code by GDS.

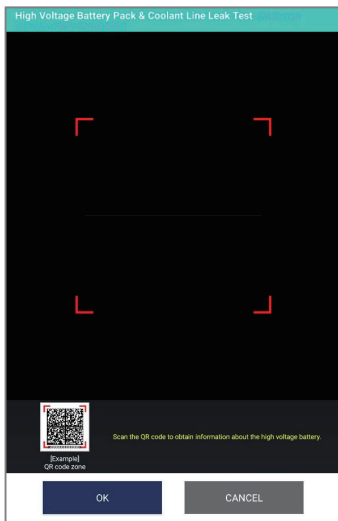

Method 1. Auto entry

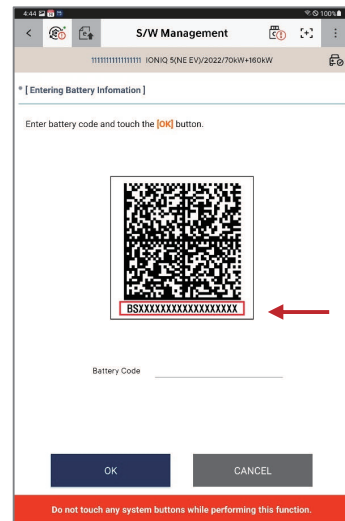

Method 2. Manual entry

※ When GDS fails to Auto entry, input the Code number to GDS manually after check it from the vehicle battery.

4. Tester Features and Test preparation

4-2. Test Preparation [GDS ↔ Tester Bluetooth Link]

1. Press the “Search” button on the GDS. (If GDS is not linked for other equipment)

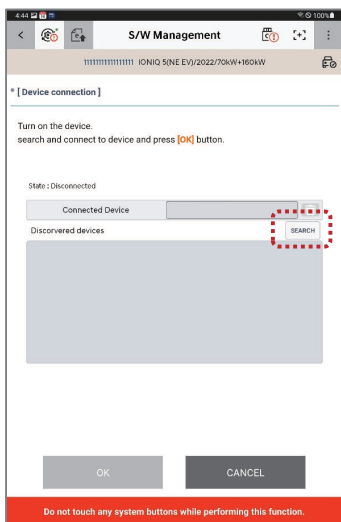

2. Select the “ULT-M100”.

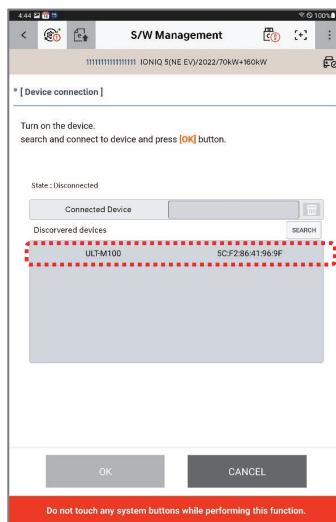

3. Press the “OK” button after checking the registration of ULT-M100 at the “Device connection”.

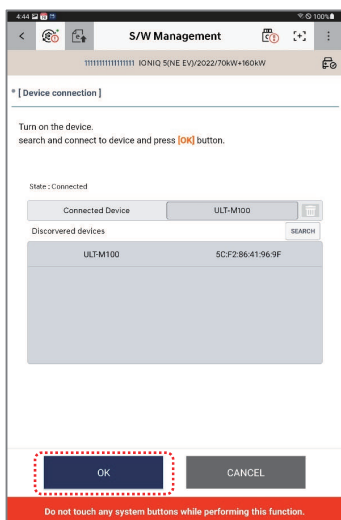

4. When Bluetooth is linked correctly, BLE LED on the tester is lighting up as blue color.



5. Test Procedure

5-1. Coolant Discharge

1. Install compressor air-connector to the SST(P/N : 09580-3D100) following sequence.

SST Information

P/N : 09580-3D100 / Name : Air Bleeding Tool / Function : Air-Decompression

※ SST is not included for ULT-M100 components

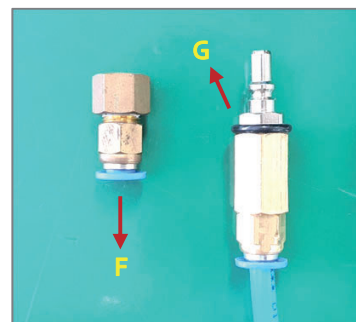
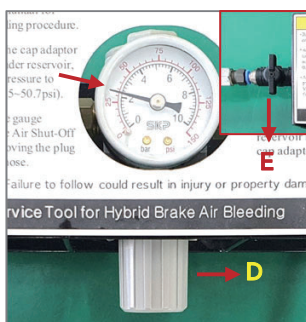
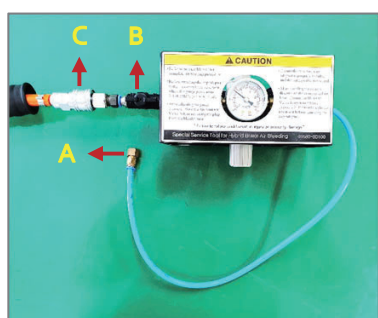

A. Check the attachment of the Block adapter. (SST basic component)

B. SST Valve open

C. Install to the Air-connector

D. Set Pressure : 2.1bar

E. Lock Valve.

F. Remove "Block adapter"
G. Install "Connection adapter"

2. Install "Coolant line fitting (IN)" to the entrance pipe of the H.V battery pack coolant line as following procedure.

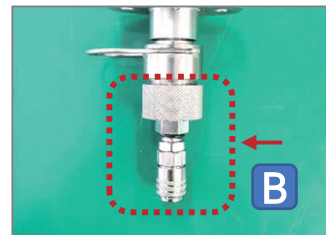
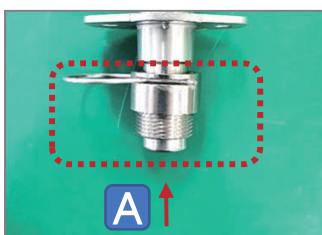

A. Check the clean status of the installation portion

B. Install "Coolant line fitting A" to the coolant pipe

C. Install "Coolant line fitting B" to the fitting A.

※ Check the correct installation of the R-pin to the pipe groove

※ Tighten the fitting B to the fitting A to do not leak occur.

5. Test Procedure

5-1. Coolant Discharge

3. Install “Coolant line fitting (OUT)” to the outlet pipe of the H.V battery pack coolant line as following procedure.



A. Check the clean status of the installation portion.

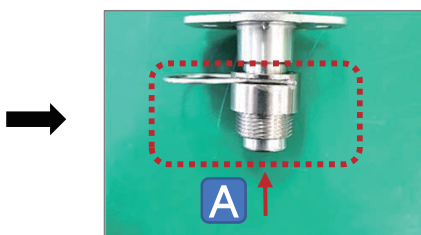

B. Install “Coolant line fitting A” to the coolant pipe

※ Check the correct installation of the R-pin to the pipe groove.

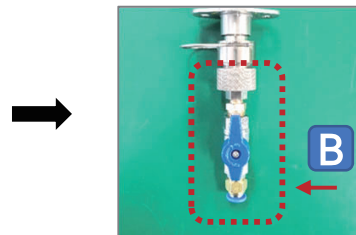

C. Install “Coolant line fitting B” to the fitting A.

※ Tighten the fitting B to the fitting to do not leak occur.

★ **Note for Coupling of Coolant line fitting A & B** ★

Grasp fitting A by finger and rotate fitting B smoothly until feel the torque in a hand then, Tighten fitting B as an additional 120 ~ 180 degree rotation.

- Excessive tightness can cause the O-ring damage and faulty fitting of R-pin
Make sure that R-Pin should be fitted for pipe groove correctly before coolant discharge .

4. Install “Coolant discharge hose” to the hose connection fitting of the coolant line (OUT) as following procedure.

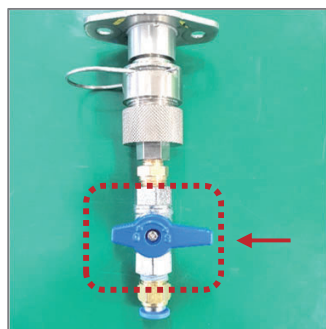

A. Lock the Valve.

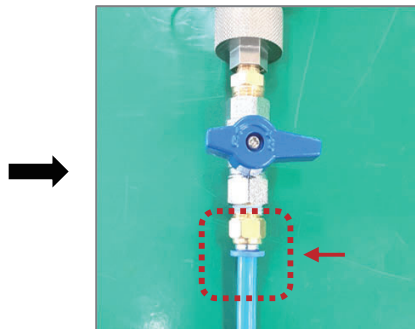

B. Connect “Coolant discharge hose”



C. Set “Coolant discharge hose” to the drain bottle.

5. Test Procedure

5-1. Coolant Discharge

5. Install “Connection adapter” which is installed with SST 09580-3D100 to the coolant fitting (IN).

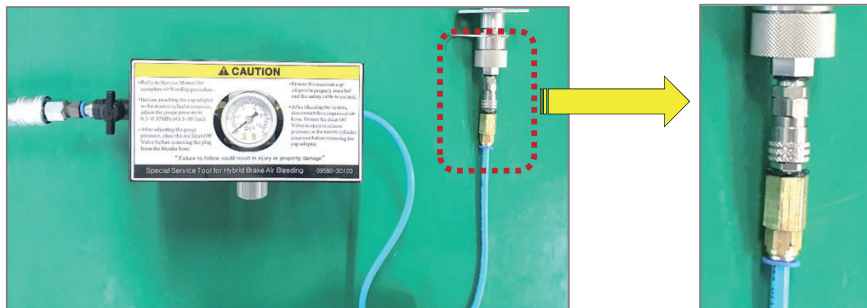

6. Discharge the coolant as following sequence.

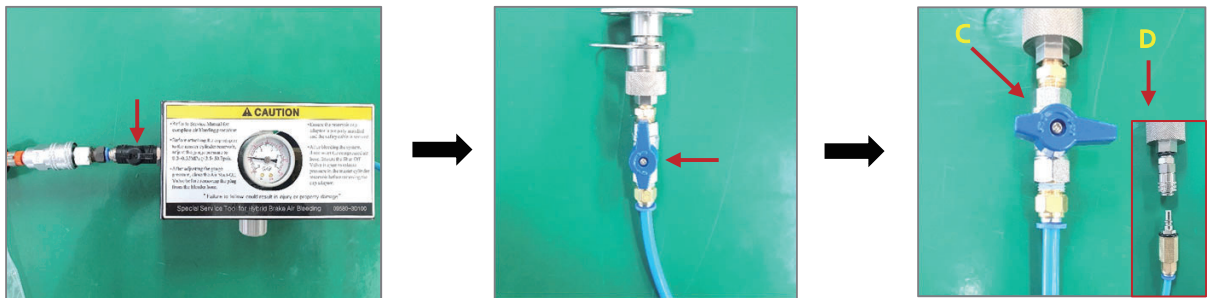

A. SST Valve open.

B. Valve open
- Coolant fitting (OUT)

C. Lock the Valve after discharge completion.

※ **Note.**
Be careful not to splash coolant into the body(Engine) by discharge pressure.

D. Remove the Connection adapter from the Coolant fitting (IN)

5. Test Procedure

5-2. Coolant Line Leak Test

1. Select “Leak Test” on the GDS.

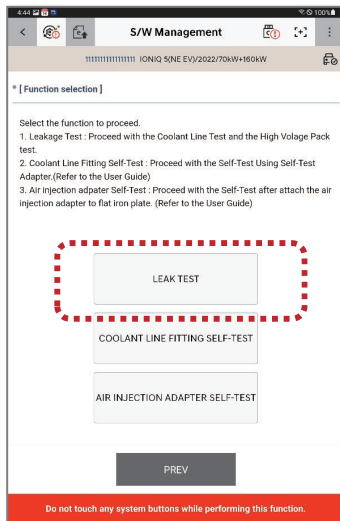

2. Press “Auto Zero” button on the GDS then, press “OK” button.



3. Install “Coolant Line Air Injection Adapter” to the Tester body and Coolant fitting (IN) of each.



A. Install “Air Injection Adapter” to the “High Pressure Air Output” Port.

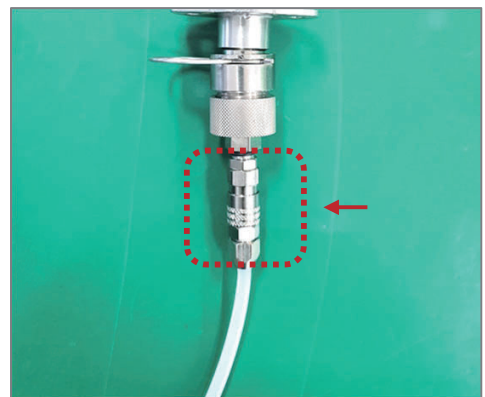

B. Install “Air Injection Adapter” to the Coolant line fitting (IN).

5. Test Procedure

5-2. Coolant Line Leak Test

4. Check the right installation of the components.

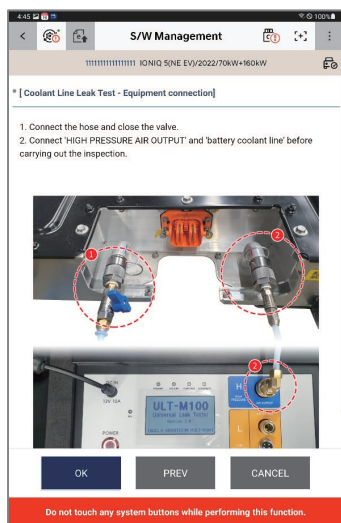

5. Press the “OK” button then, Test will be auto-implementation.

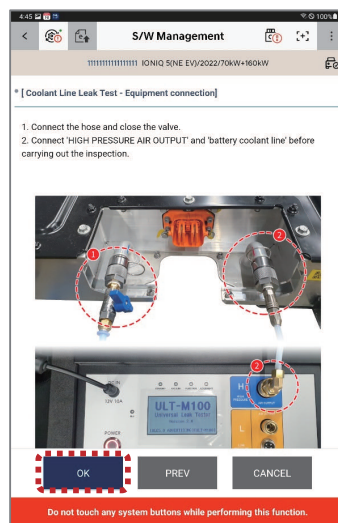

6. The Test result is displayed as showed below after test completion.

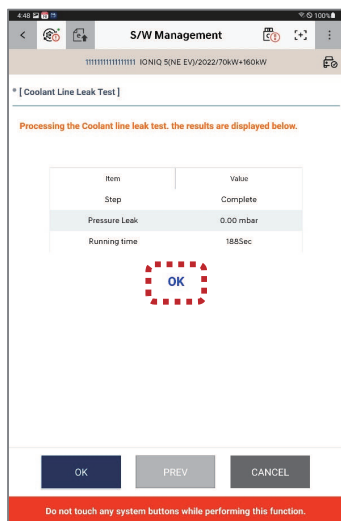

Result	Action
PASS (OK)	Test termination
FAIL (NG)	Implement Coolant fitting IN/OUT Self-Test (Refer to Page 18)

5. Test Procedure

5-3. Self Test [Coolant Fitting (IN/OUT)]

■ Purpose of Self Test

- "It is to check the source(coolant line of battery pack case or tester) of pressure leakage for the fail judgement.

1. Install "Coolant line fitting (IN)" to the Self-test adapter as following procedure.

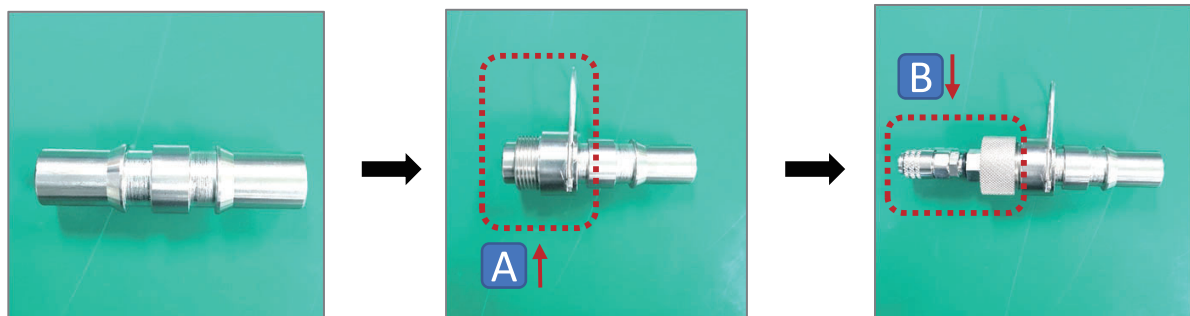

A. Prepare Self-test adapter.

B. Install "Coolant line fitting A" to the Self-test adapter.

※ Check the correct installation of the R-pin to the self-test adapter groove.

C. Install "Coolant line fitting B" to the fitting A.

※ Tighten the fitting B to the fitting A to do not leak occur.

2. Install "Coolant line fitting (OUT)" to the Self-test adapter as following procedure.

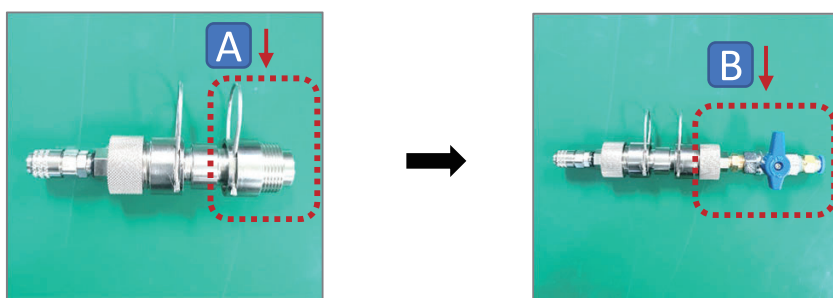

A. Install "Coolant line fitting A" to the Self-test adapter.

※ Check the correct installation of the R-pin to the self-test adapter groove.

B. Install "Coolant line fitting B" to the fitting A.

※ Tighten the fitting B to the fitting A to do not leak occur.

★ Note for Coupling of Coolant line fitting A & B ★

Grasp fitting A by finger and rotate fitting B smoothly until feel the torque in a hand then, Tighten fitting B as an additional 120 ~ 180 degree rotation. Make sure that R-Pin should be fitted for self-test adapter groove correctly.

5. Test Procedure

5-3. Self Test [Coolant Fitting (IN/OUT)]

3. Install “Coolant Line Air Injection Adapter” to the Tester body and Coolant fitting (IN) of each.



A. Install “Air Injection Adapter” to the “High Pressure Air Output” Port.

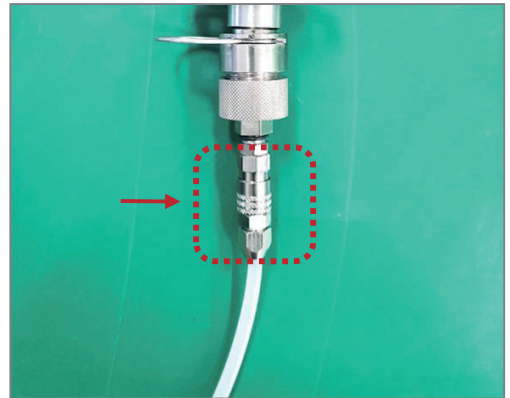

B. Install “Air Injection Adapter” to the Coolant line fitting (IN).

4. Perform “Self Test-Coolant Line Fitting” on the GDS.

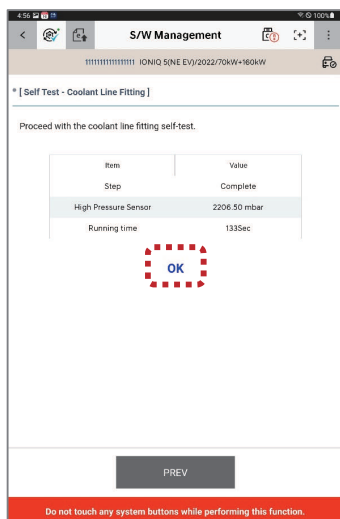

Result	Action	
PASS (OK)	Keep previous judgment	
FAIL (NG)	Step 1	Exchange coolant line fitting (IN/OUT) silicon Flat O-ring (Refer to Page 24)
	Step 2	Implement again coolant line leak test.

5. Test Procedure

5-4. Battery Pack Leak Test

■ Application of Sealing connectors for Vehicle [Reference Only]

Vehicle	Sealing Connector Name							
	Main [E001]	Main (New) [E002]	Heating [E003]	Communication [E004]	Quick Charge [E005]	FR DC [E006]	RR DC [E007]	ICCU DC [E008]
OS EV (19MY)	●		●	●				
OS EV (20MY~)		●	●	●				
AE EV (19MY)	●		●	●	●			
AE EV (20MY~)		●	●	●	●			
HR EV	●		●	●				
NE				●		●	●	●

※ The above application is reference only, thus be sure to check correct connector information from the shop-manual before the test.

■ Parts Installation Guide of Safety Plug(Service Plug) application vehicle.

Item	Step 1	Step 2
Test Before	Install tester parts	Install Safety Plug (Uninstallation – Leak occurs during Test)
Test After	Remove Safety Plug (Promptly)	Remove tester parts



**Safety Plug
(Service Plug)**

※ CAUTION

- Engineer have to comply with the above Parts Installation Guide at the test before/after.
Wrong installation removal of Safety Plug can be caused for electric shock problem.

5. Test Procedure

5-4. Battery Pack Leak Test

1. Remove connectors from the H.V Battery pack then, install Sealing connectors to the Battery pack.



2. Connect “Pressure sensor module” to the Tester.

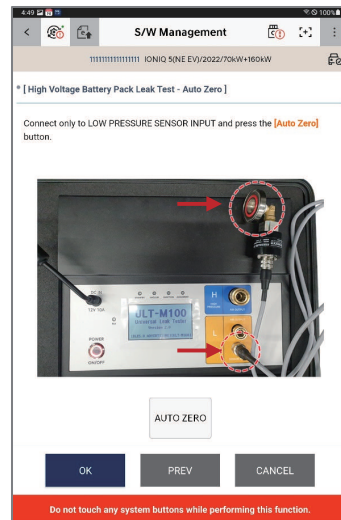

3. Select “Auto Zero” from the KDS.



4. Install various connection parts to the Tester and H.V Battery pack.



5. Test Procedure

5-4. Battery Pack Leak Test

5. Perform Test on the GDS after check all of parts are correctly installed.

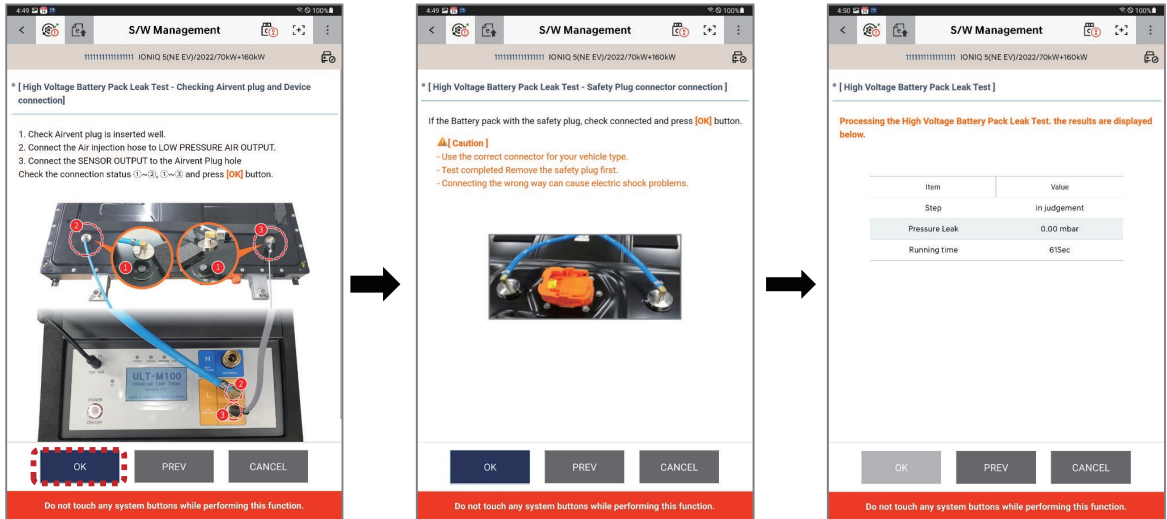

A. Select “OK” button.

B. check for safety plug installation.

C. Test Implementation

6. The Test result is displayed below after test completion.

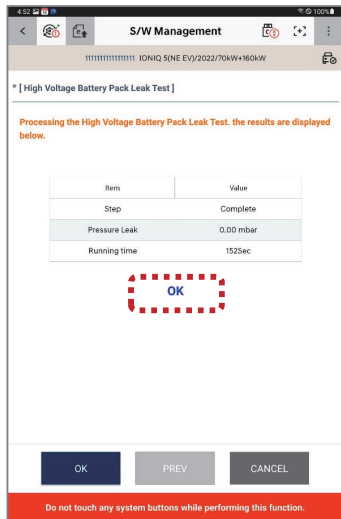

Result	Action
PASS (OK)	Test Termination
FAIL (NG)	Implement Battery pack air injection adapter Self-test (Refer to Page 23)

5. Test Procedure

5-5. Self Test [Battery Pack Air Injection Adapter]

■ Purpose of Self Test

- "It is to check the source(battery pack case or tester) of pressure leakage for the fail judgement.

1. As shown below the photo, attach the “Air injection adapter” to the flat and seamless steel plate and connect the coupler to the tester.



2. Perform “Self Test - Air Injection Adapter” on the GDS.

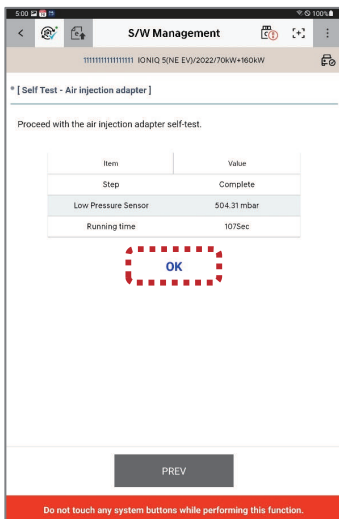

Result	Action	
PASS (OK)	Keep previous judgment	
FAIL (NG)	Step 1	Exchange silicon O-ring of Air injection adapter. (Refer to Page 24)
	Step 2	Implement again Battery pack leak test

6. Switching Method of Spare Parts

6-1. Air Injection Adapter/Pressure Sensor Module O-Ring (Battery Pack)



A. Remove existing O-ring



B. Remove foreign material
(Use repair tissue)

※ Prohibit Air blow gun use for Pressure sensor module when foreign material cleaning. (Pressure sensor break)



C. Install new O-ring

6-2. Coolant Fitting Flat O-Ring (IN/OUT)



A. Remove existing Flat O-ring

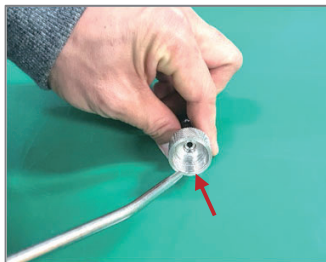

B. Cleaning by Air blow gun
(Foreign material removal)



C. Install new Flat O-ring

6-3. Coolant Fitting R-Pin (IN/OUT)

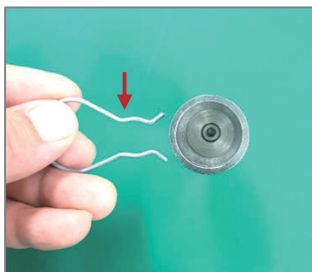

A. Remove existing R-pin



B. Install new R-pin

7. Warranty / Certification

7-1. Warranty

Item	Warranty Period
Main Test Unit	2 years from the purchasing date
Accessories	

※ Tester fault /damage/break cause by user negligence, mistake or wrong operation will be releasing to the repair cost arising of user.

7-2. Certification



Note : This equipment has been tested and found to comply with the Limits for a Class A digital device, pursuant to part 15 of the FCC Rules. These Limits are designed to provide reasonable protection against harmful Interference when the equipment is operated in a commercial environment. This equipment generates, uses, and can radiate radio frequency energy and , if not installed and used in accordance with the instruction manual, may cause harmful interference to radio communications. Operation of this equipment in a residential area is likely to cause harmful interference in which case the user will be required to correct the interference at his own expense.



R-R-UJA-ULT-M100
RF Module : R-C-csi-BoT-nLE521



Universal Leak Tester

ULT-M100



GIT Co., Ltd

GIT Building Machun-ro 87, Songpa-Gu, Seoul Korea

Tel : 02 2189 3300

Email : sales@gitauto.com

Web : www.gitauto.com

통합 기밀 검사장비

사용자 가이드



ULT-M100

 **HYUNDAI**

목차

1. 제품 개요	2
2. 안전 사항	
2-1. 고전압 부품 취급 주의 사항	3
2-2. 장비 활용 주의사항	3
3. 제품 사양 및 구성품	
3-1. 제품 사양	4
3-2. 구성품	5
4. 본체 각부 명칭 및 테스트 준비	
4-1. 본체 각부 명칭	8
4-2. 테스트 준비	9
5. 테스트 절차	
5-1. 냉각수 배출	13
5-2. 냉각수로 기밀 테스트	16
5-3. 셀프 테스트 [냉각수 피팅(IN/OUT)]	18
5-4. 배터리팩 기밀 테스트	20
5-5. 셀프 테스트 [배터리팩 에어 주입 어댑터]	23
6. 스페어 파트 교체 방법	
6-1. 에어주입 어댑터/압력센서 모듈(배터리팩) 오링 교체 방법	24
6-2. 냉각수 피팅(IN/OUT) 각링 교체 방법	24
6-3. 냉각수 피팅(IN/OUT) R핀 교체 방법	24
7. 제품 보증 / 제품 인증	25

1. 제품 개요

본 장비는 고전압 배터리팩의 안정성 유지에 필요한 기밀 상태를 정확하고 정밀하게 확인하기 위하여, 배터리팩 냉각수로 및 케이스에 적정압력을 가압 후 일정시간 동안 누설압력을 디지털방식으로 측정하는 검사장비입니다.

- 진단 범위

고전압 배터리팩 냉각수로, 고전압 배터리팩 케이스의 내부 기밀 유지 확인

- 사용 목적

본 장비는 압력 가압을 통해 기밀상태를 정확하게 진단하는 것에 중점을 두고 있습니다.

전동화 차량에 장착된 고전압 배터리팩은 외부적인 요인(물, 습기, 기타 이물질)으로부터 보호되어야 함으로 항상 기밀상태가 유지되어야 합니다.

워크샵에서 고전압 배터리팩 케이스를 교체하거나 케이스 오픈 후 부분 정비(팩/모듈/셀)가 이뤄졌을 경우 반드시 본장비를 활용하여 기밀상태를 최종적으로 확인하십시오.

2. 안전 사항

2-1. 고전압 부품 취급 시 주의 사항

- 고전압 시스템을 점검하거나 정비하기전에 , 반드시 안전플러그를 분리하여 고전압을 차단한다.
- 금속성 물질은 고전압 단락을 유발하여 인명과 차량을 손상시킬 수 있으므로 반드시 몸에서 제거한다. (시계, 반지, 기타 금속성 제품 등)
- 고전압 관련 작업전에는 안전 사고 예방을 위해 개인 보호 장구를 착용한다.
- 보호 장비를 착용한 작업 담당자 이외에는 고전압 부품과 관련된 부분을 절대 만지지 못하도록 한다.

2-2. 제품 활용 시 주의 사항

- 장비 사용 전/후 구성품의 이물질 제거하고 청결한 상태를 유지한다.
- 사용 전 반드시 매뉴얼 숙지하여 절차와 지침을 따른다.
- 사용에 앞서 반드시 자동차의 제조사에서 발행한 차량관리 안전 지침을 숙지한다.
- 환기가 잘되는 곳에서만 장비를 사용하고 보호장구(보호안경, 보호장갑 등)를 착용한다.
- 외부 충격에 의해 장비가 파손되었을 경우 즉시 사용을 멈추고 수리가 필요할 경우 반드시 장비 제조사에 의해 수리를 받는다. (비정상적인 수리는 장비 파손의 원인이 될 수 있음)
- 장비를 비 또는 눈에 노출시키지 않는다.
- 장비를 제조목적 이외의 용도로 사용하지않는다.
- 장비가 차량에 설치된 상태에서 방치하지 않는다.
- 장비를 작동 온도 범위(0 ~ 40℃)에서 사용하지않을 경우 고장의 원인이 될 수 있습니다.

3. 제품 사양 및 구성품

3-1. 제품 사양







항목		제원	
디스플레이		LCD : 240*128(DOT) / BLU	
상태 표시 LED		4 Color LED	
무선 통신		Bluetooth V5.0(BLE)	
알람		Buzzer (75db / 2600Hz)	
압력센서	냉각수로	주입/측정	측정 범위 : 0 ~ 4bar 정확도 : ±0.25% FS
	배터리팩	주입	측정 범위 : -0.5 ~ +0.5bar 정확도 : ±0.25% FS
		측정	측정 범위: 0 ~ 5Kpa 정확도 : ±0.25% FS
전원 입력		DC 12V / 10A	
최대 소비 전력		MAX. 60W	
사용 온도		0°C ~ 40°C	
제품 인증		KC / CE / FCC	

3. 제품 사양 및 구성품

3-2. 구성품

품명	품번	이미지	수량	비고
메인 케이스 [메인 테스트 유닛]	G7XHDNN002		1EA	
액세서리 케이스 [액세서리]	G7XHDNN003		1EA	
검사장비 본체	G7XHDNN005		1EA	
전원 어댑터	G7XHDNN006		1EA	
에어주입 어댑터 [배터리팩 용]	G7XHDNN007		1EA	
압력센서 모듈 [배터리팩 용]	G7XHDNN008		1EA	
에어주입 어댑터 [냉각수로 용]	G7XHDNN009		1EA	

3. 제품 사양 및 구성품

품명	품번	이미지	수량	비고
냉각수로 피팅 [In]	G7XHDNN010		1EA	냉각수로 Inlet
냉각수로 피팅 [Out]	G7XHDNN011		1EA	냉각수로 Outlet
냉각수 배출호스	G7XHDNN012		1EA	
연결 어댑터 [냉각수 배출용]	G7XHDNN013		1EA	
셀프 테스트 어댑터	G7XHDNN014		1EA	냉각수로 기밀검사 셀프 테스트 용
씰링 커넥터 [Main] [E001]	G7XHDNN015		1EA	
씰링 커넥터 [Main/New] [E002]	G7XHDNN016		1EA	
씰링 커넥터 [Heating] [E003]	G7XHDNN017		1EA	

3. 제품 사양 및 구성품

품명	품번	이미지	수량	비고
씰링 커넥터 [Communication] [E004]	G7XHDNN018		1EA	
씰링 커넥터 [Quick Charge] [E005]	G7XHDNN019		1EA	
씰링 커넥터 [FR DC] [E006]	G7XHDNN020		1EA	
씰링 커넥터 [RR DC] [E007]	G7XHDNN021		1EA	
씰링 커넥터 [ICCU DC] [E008]	G7XHDNN022		1EA	
스페어 파츠	G7XHDNN023		1 SET	오링 : 6EA 각링 : 4EA R핀 : 2EA
사용자 가이드	G7XHDNN004		1EA	

4. 본체 각부 명칭 및 테스트 준비

4-1. 본체 각부 명칭

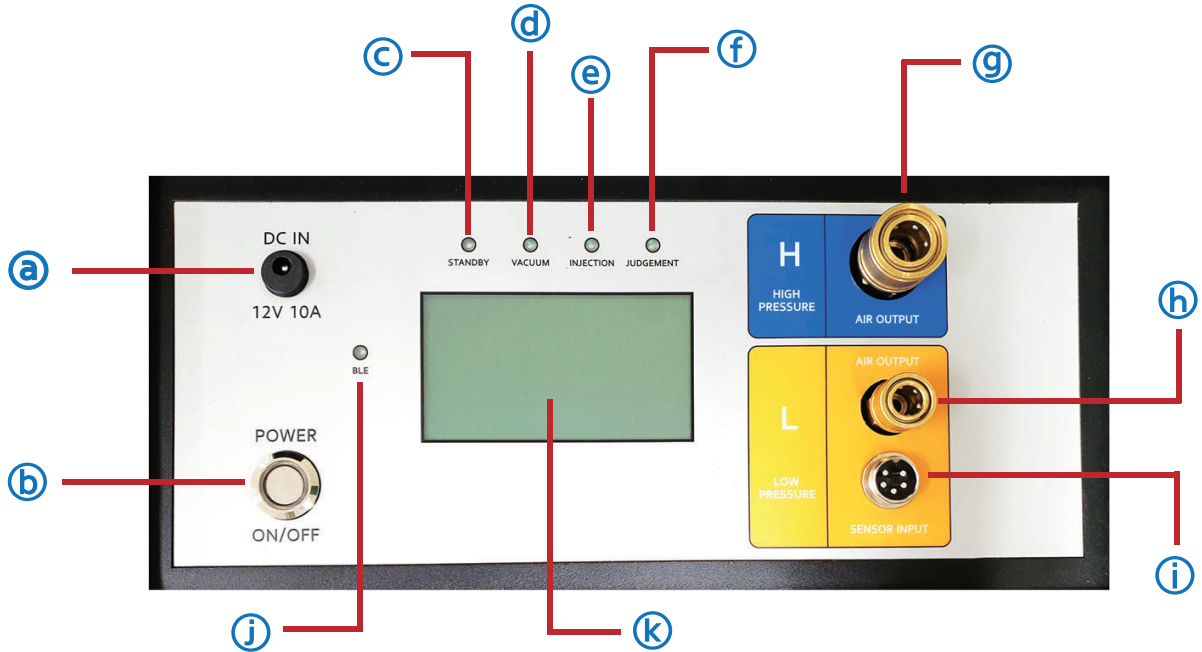

기호	명칭	기능설명
㉑	DC IN	본체 전원 잭(12V 10A)
㉒	POWER	본체 전원 스위치(ON/OFF)
㉓	STANDBY LED	장비 운용 준비 완료 알림
㉔	VACUUM LED	에어펌프 구동 알림(부압)
㉕	INJECTION LED	에어펌프 구동 알림(정압)
㉖	JUDGEMENT LED	판정 알림
㉗	HIGH PRESSURE AIR OUTPUT	냉각수로 에어 토출부
㉘	LOW PRESSURE AIR OUTPUT	배터리팩 에어 토출부
㉙	LOW PRESSURE SENSOR INPUT	배터리팩 압력 측정부
㉚	BLE LED	블루투스 연결 상태 표시
㉛	LCD	구동 정보 디스플레이

4. 본체 각부 명칭 및 테스트 준비

4-2. 테스트 준비 [본체 전원공급]

1. 전원 잭을 본체에 체결합니다.

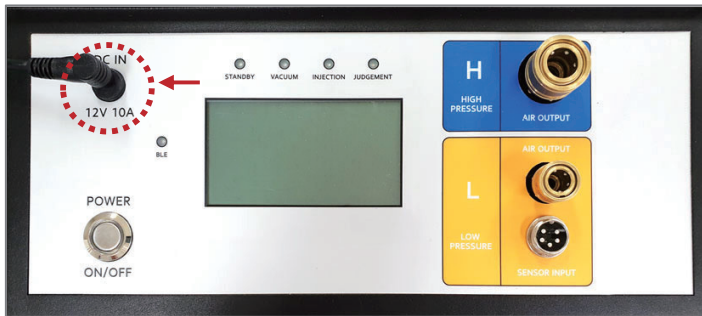

2. 본체 전원 스위치를 누릅니다.

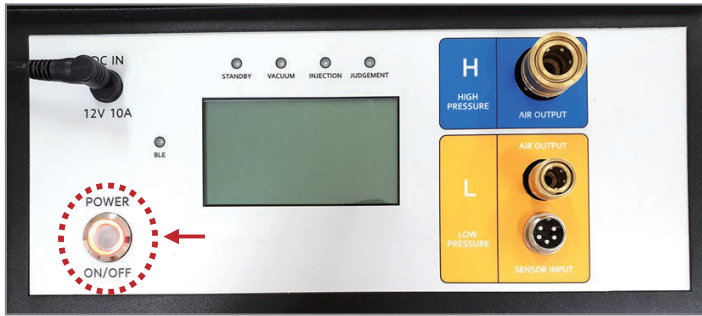

3. 전원 공급 완료

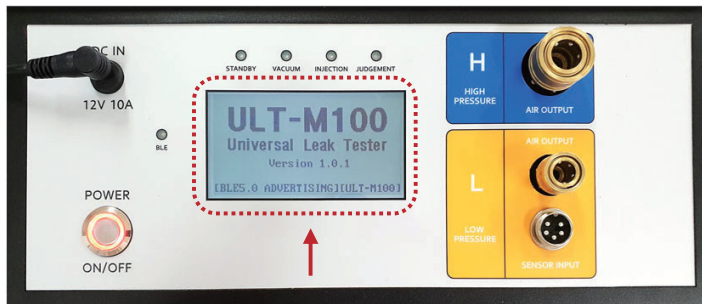

4. 본체 각부 명칭 및 테스트 준비

4-2. 테스트 준비 [차종 선택]

1. 'Tool Box' 를 선택합니다.



[GDS Smart]

2. '부가기능' 을 선택합니다.



[GDS Smart]



[GDS]

3. 테스트 차종을 선택합니다.



4. '고전압 배터리 팩 및 냉각수 라인 기밀 점검' 기능을 선택합니다.

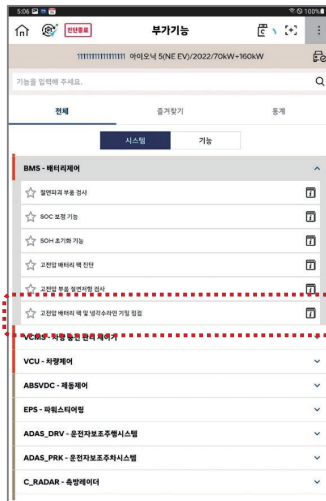

5. 하단 '실행' 버튼을 누릅니다.

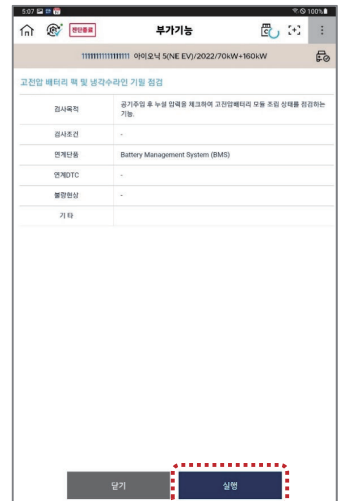

4. 본체 각부 명칭 및 테스트 준비

4-2. 테스트 준비 [QR 코드 스캔]

1. 고전압 배터리팩의 QR코드를 진단기로 스캔하여 줍니다.

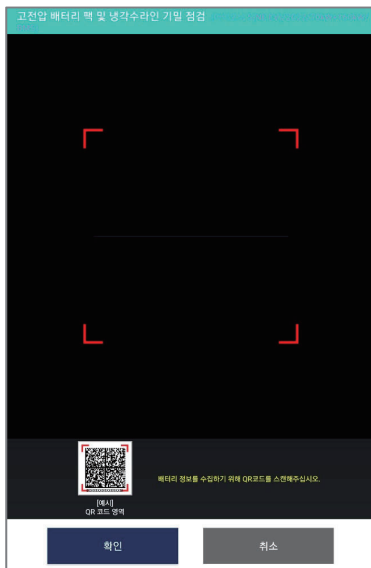

방법1. 자동 입력



방법2. 수동 입력

※ 자동 입력이 안될 경우 차량의 배터리에서 코드번호를 확인하여 진단기에 수동으로 입력하십시오.

4. 본체 각부 명칭 및 테스트 준비

4-2. 테스트 준비 [진단기 ↔ 본체 블루투스 연결]

1. 현재 연결된 장비가 없는 경우 ‘검색’ 버튼을 눌러 장비 검색을 진행하여 주십시오.

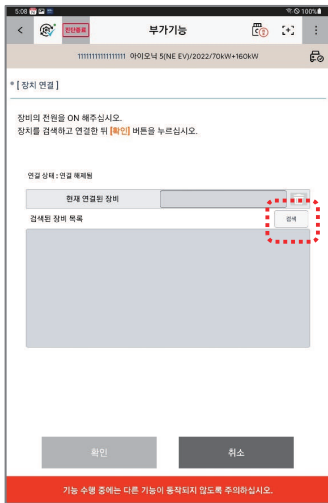

2. 검색된 장비를 선택합니다.

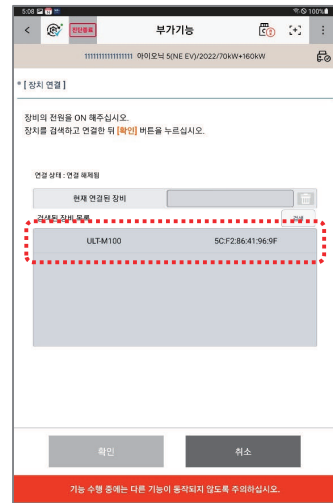

3. 선택 한 장비가 현재 연결된 장비에 등록 된 후 ‘확인’ 버튼을 눌러 주십시오.

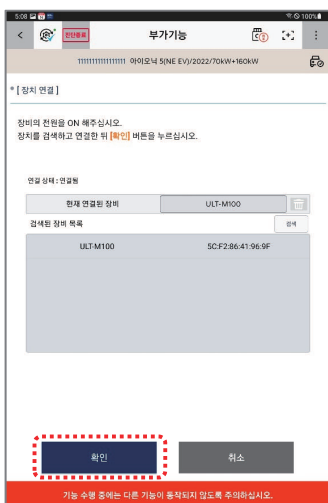

4. 블루투스가 정상적으로 연결이 되면 장비 본체의 BLE LED가 파란색으로 점등이 됩니다.



5. 테스트 절차

5-1. 냉각수 배출

1. 아래 순서에 따라 SST(P/N : 09580-3D100)에 콤프레샤 에어 커넥터를 체결합니다.

SST 정보

품번 : 09580-3D100 / 품명 : 에어 블리딩 툴 / 기능 : 에어 압력 감압
 ※ SST는 구성품에 미포함

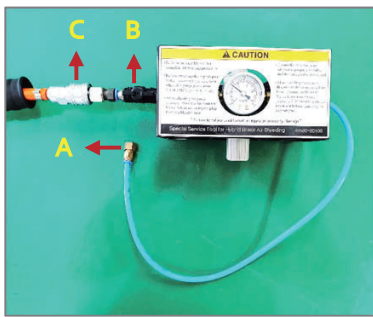

A. 블록 어댑터 체결 확인
 (SST 기본 구성품)
 B. SST 밸브 오픈
 C. 에어 커넥터 체결

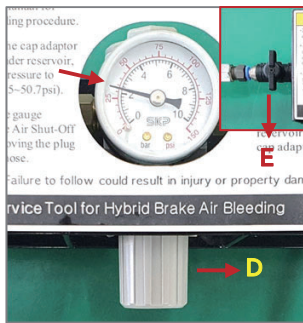

D. 압력 설정
 (설정 압력 : 2.1bar)
 E. 밸브 잠금

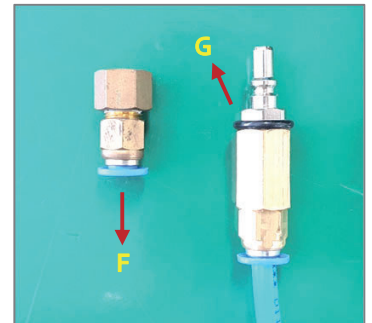

F. 블록 어댑터 탈거
 G. 구성품 “연결 어댑터” 체결

2. 고전압 배터리팩의 냉각수로 입구 측 파이프에 구성품 “냉각수로 피팅(IN)을 아래 절차에 따라 체결 하십시오.



A. 체결부 청결상태 확인

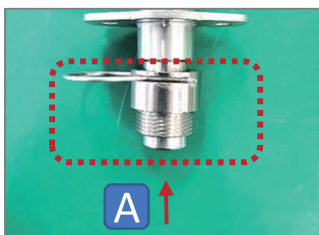

B. 구성품 냉각수로 피팅 A 체결(R핀측)
 ※ R핀이 파이프 홈에 정확히 체결 되었는지 확인합니다.



C. 구성품 냉각수로 피팅 B 체결
 ※ 테스트간 압력누설이 발생하지 않도록 피팅 B를 피팅 A에 충분히 조여줍니다.

5. 테스트 절차

5-1. 냉각수 배출

3. 고전압 배터리팩의 냉각수로 출구 측 파이프에 구성품 “냉각수로 피팅(OUT)”을 아래 절차에 따라 체결 하십시오.



A. 체결부 청결상태 확인

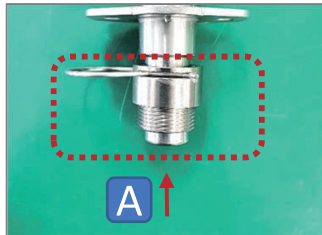

B. 구성품 냉각수로 피팅 A 체결(R핀측)

※ R핀이 파이프 홈에 정확히 체결 되었는지 확인합니다.

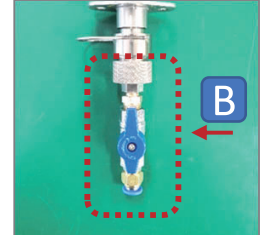

C. 구성품 냉각수로 피팅 B 체결

※ 테스트간 압력누설이 발생하지 않도록 피팅 B를 피팅 A에 충분히 조여줍니다.

★ 냉각수로 피팅 A와 피팅 B의 결합 시 주의사항 ★

손가락으로 피팅 A를 잡고, 피팅 B를 토크가 느껴질 때까지 천천히 회전시킨다.
이후 다시 피팅 B를 120~180도 정도 추가로 회전시켜 조여준다.

- 과도한 조임은 O-ring 파손 및 동작 시 R-Pin 체결 이탈의 원인이 될 수 있음.

냉각수 배출 전 R-Pin이 파이프 홈에 정확히 장착되었는지 다시한번 반드시 확인한다.

4. “냉각수로 피팅(OUT)부의 호스 연결 피팅부에 구성품 “냉각수 배출 호스”를 아래 절차에 따라 체결하십시오.

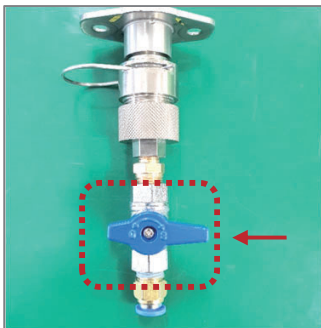

A. 밸브 잠금

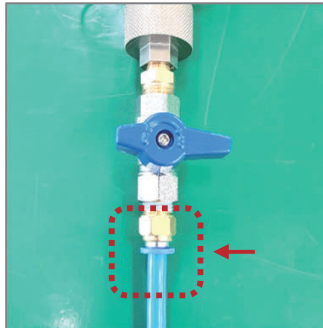

B. 냉각수 배출 호스 체결



C. 드레인 보트에 배출 호스 거치

5. 테스트 절차

5-1. 냉각수 배출

5. 냉각수 피팅 [IN] 부에 SST 09580-3D100과 체결된 “연결어댑터”를 체결합니다.

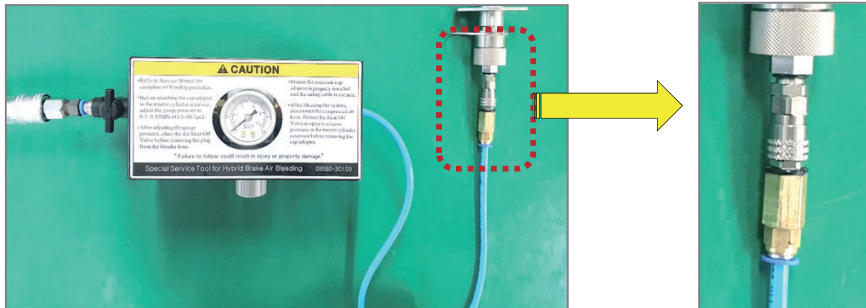

6. 아래 순서에 따라 냉각수를 배출합니다.

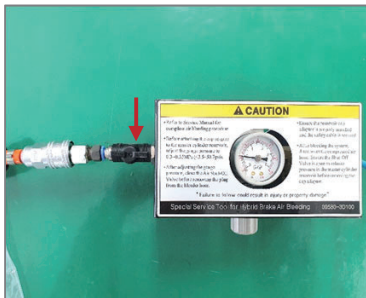

A. SST 밸브 오픈

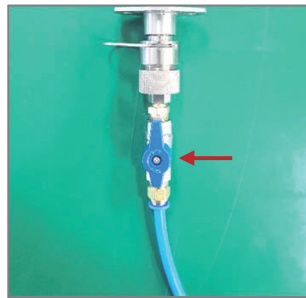

B. 밸브 오픈(냉각수 피팅 OUT)

※ 배출 압력에 의해 냉각수가 신체에 튀지 않도록 반드시 주의하십시오.

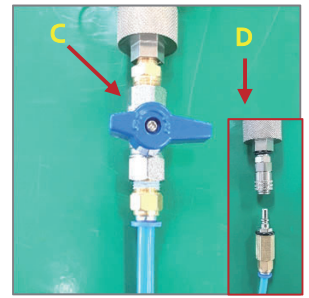

C. 냉각수 배출 완료시 밸브잠금

D. 냉각수 피팅 IN부에 체결된 연결 어댑터 탈거

5. 테스트 절차

5-2. 냉각수로 기밀 테스트

1. 진단기에서 ‘기밀점검’ 을 선택합니다.

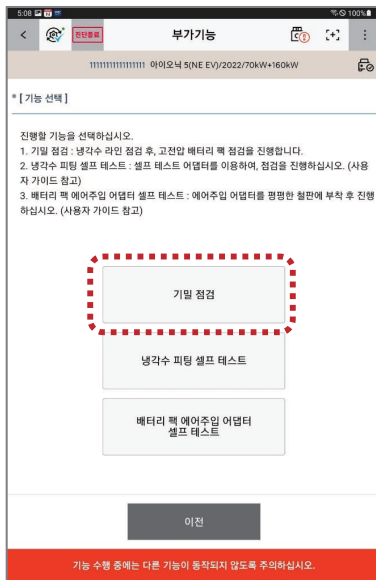

2. 진단기에서 ‘영점 조정’ 버튼 누르고 ‘확인’ 버튼을 누릅니다.



3. 구성품 “냉각수로 에어주입어댑터”를 장비 본체와 냉각수 피팅(IN)에 각각 체결합니다.



A. 본체 High Pressure Air Output 포트에 구성품 “에어주입 어댑터” 체결.

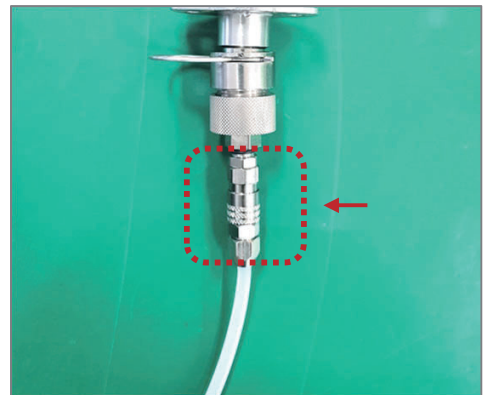

B. 냉각수로 피팅(IN)에 구성품 “에어주입 어댑터” 체결

5. 테스트 절차

5-2. 냉각수로 기밀 테스트

4. 구성품이 올바르게 체결되었는지 확인합니다.

5. “확인” 버튼을 누르면 테스트가 자동실행 됩니다.

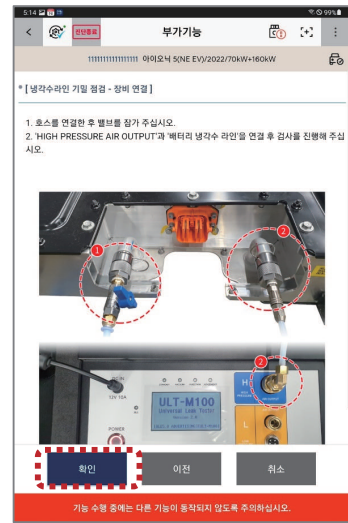

6. 테스트가 완료되면 그림과 같이 테스트 결과값이 표출됩니다.

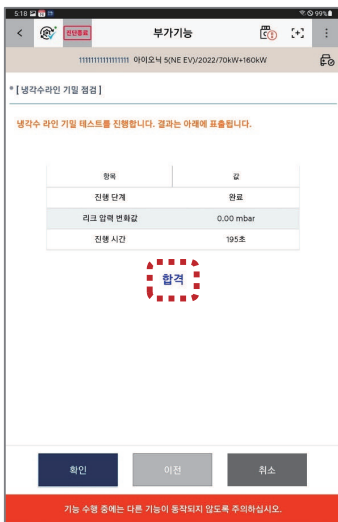

테스트 결과	조치
PASS (합격)	테스트 종료
FAIL (불합격)	냉각수 피팅 IN/OUT 셀프 테스트 수행 (Page 18 참고)

5. 테스트 절차

5-3. 셀프 테스트 [냉각수 피팅(IN/OUT)]

■ 셀프 테스트 목적

- 직전 테스트 Fail 판정에 대한 압력누설이 차량의 냉각수로에서 발생하는지, 장비에서 발생하는지 확인하기 위함.

1. 셀프 테스트 어댑터에 구성품 “냉각수로 피팅(IN)”을 아래 절차에 따라 체결 하십시오.

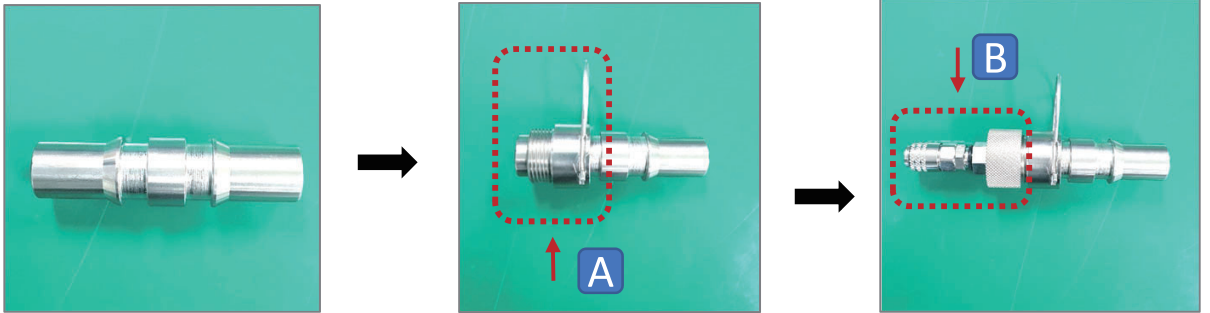

A. 구성품 셀프 테스트 어댑터 준비

B. 구성품 냉각수로 피팅 A 체결(R핀측)

※ R핀이 파이프 홈에 정확히 체결되었는지 확인합니다.

C. 구성품 냉각수로 피팅 B 체결

※ 테스트간 압력누설이 발생하지 않도록 피팅 B를 피팅 A에 충분히 조여줍니다.

2. 셀프 테스트 어댑터에 구성품 “냉각수로 피팅(OUT)”을 아래 절차에 따라 체결 하십시오.

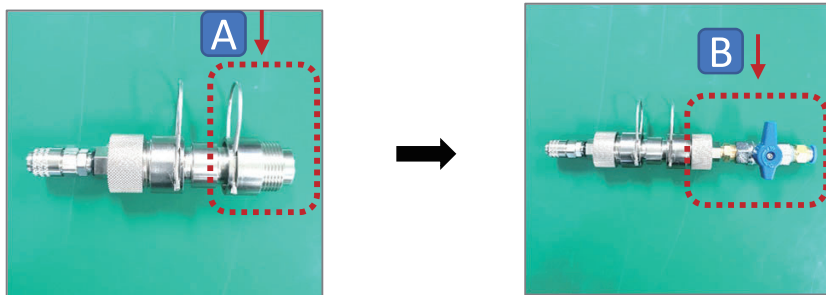

A. 구성품 냉각수로 피팅 A 체결(R핀측)

※ R핀이 파이프 홈에 정확히 체결되었는지 확인합니다.

B. 구성품 냉각수로 피팅 B 체결

※ 테스트간 압력누설이 발생하지 않도록 피팅 B를 피팅 A에 충분히 조여줍니다.

★ 냉각수로 피팅 A와 피팅 B의 결합 시 주의사항 ★

손가락으로 피팅 A를 잡고, 피팅 B를 토크가 느껴질 때까지 천천히 회전시킨다.
이후 다시 피팅 B를 120~180도 정도 추가로 회전시켜 조여준다.

- 과도한 조임은 O-ring 파손 및 동작 시 R-Pin 체결 이탈의 원인이 될 수 있음.
테스트전 R-Pin이 파이프 홈에 정확히 장착되었는지 다시한번 반드시 확인한다.

5. 테스트 절차

5-3. 셀프 테스트 [냉각수 피팅(IN/OUT)]

3. 구성품 “냉각수로 에어주입 어댑터”를 장비 본체와 냉각수 피팅(IN)에 각각 체결합니다.



A. 본체 High Pressure Air Output 포트에 구성품 “에어주입 어댑터” 체결.

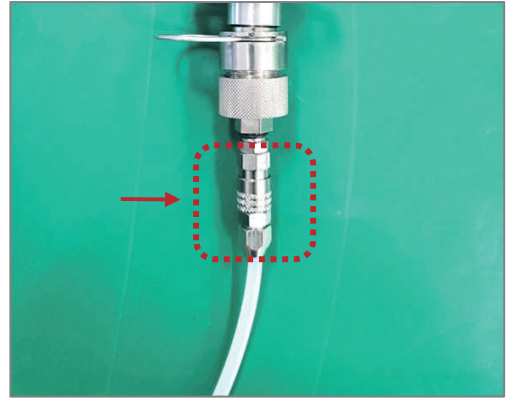

B. 냉각수로 피팅(IN)에 구성품 “에어주입 어댑터” 체결

4. 진단기에서 냉각수 피팅 셀프 테스트 기능을 실행합니다.

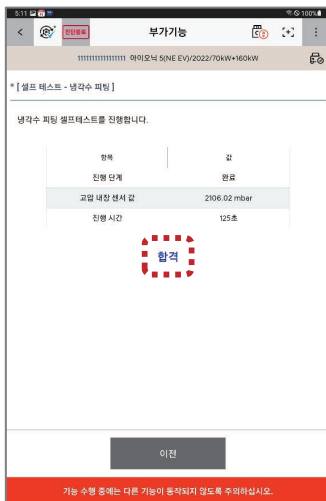

테스트 결과	조치	
PASS (합격)	직전 판정 유지	
FAIL (불합격)	Step 1	냉각수 피팅(IN/OUT) 실리콘 각링 교체 (Page 24 참고)
	Step 2	냉각수로 기밀 테스트 재 실행

5. 테스트 절차

5-4. 배터리팩 기밀 테스트

■ 차종별 막음 커넥터 적용표 [Reference Only]

Vehicle	Sealing Connector Name							
	Main [E001]	Main (New) [E002]	Heating [E003]	Communication [E004]	Quick Charge [E005]	FR DC [E006]	RR DC [E007]	ICCU DC [E008]
OS EV (~19MY)	●		●	●				
OS EV (20MY~)		●	●	●				
AE EV (19MY)	●		●	●	●			
AE EV (20MY~)		●	●	●	●			
HR EV	●		●	●				
NE				●		●	●	●

※ 상기 자료는 참고용으로 테스트 전 반드시 워크샵 매뉴얼에서 적용 커넥터 정보를 확인 바랍니다.

■ 안전플러그(서비스 플러그) 적용 차종 구성품 설치 가이드

구분	Step 1	Step 2
테스트 전	장비 구성품 설치	안전플러그 체결 (미체결시 테스트간 리크발생)
테스트 후	(즉시)안전플러그 탈거	장비 구성품 탈거



-안전 플러그(서비스 플러그)-

※ 주의사항

- 테스트 전/후 위 구성품 설치 가이드를 반드시 준수 하십시오. 안전 플러그의 잘못된 장착 및 탈거는 전기적 쇼크 문제를 일으킬 수 있습니다.

5. 테스트 절차

5-4. 배터리팩 기밀 테스트

1. 고전압 배터리팩에 체결되어 있는 커넥터를 탈거 후 막음 커넥터를 그림과 같이 체결합니다.



2. 구성품 “압력센서 모듈”을 장비 본체에 연결합니다.



3. 진단기에서 ‘영점 조정’ 을 선택 합니다.



4. 그림과 같이 본체 및 고전압 배터리팩에 구성품을 설치합니다.



5. 테스트 절차

5-4. 배터리팩 기밀 테스트

5. 구성품 체결이 정상적인지 확인 후 이상이 없을 시 진단기에서 테스트를 실행 합니다.



A. 하단 '확인' 버튼 선택

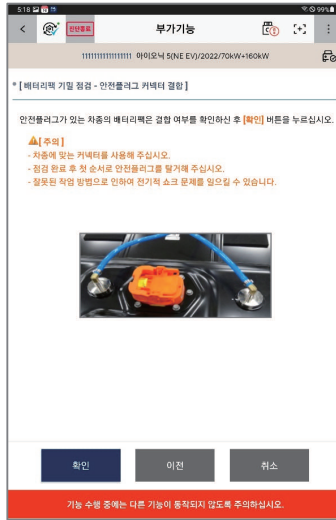

B. 안전플러그 체결 확인

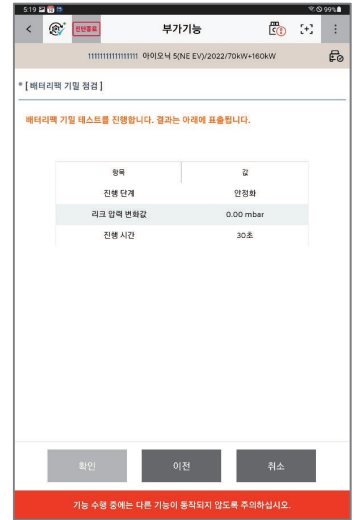

C. 테스트 실행

6. 테스트가 완료되면 그림과 같이 테스트 결과값이 표출됩니다.

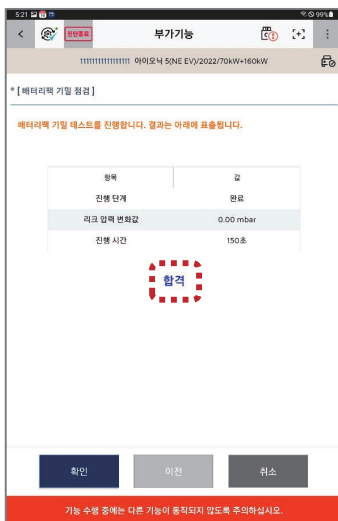

테스트 결과	조치
PASS (합격)	테스트 종료
FAIL (불합격)	배터리팩 에어주입 어댑터 셀프 테스트 수행 (Page 23 참고)

5. 테스트 절차

5-5. 셀프 테스트 [배터리팩 에어 주입 어댑터]

■ 셀프 테스트 목적

- 직전 테스트 Fail 판정에 대한 압력누설이 차량의 배터리팩에서 발생되는지, 장비에서 발생하는지 확인하기 위함.

1. 아래 그림과 같이 에어주입 어댑터를 평평하고 매끄러운 스틸 플레이트에 부착 후 커플러는 본체에 체결합니다.



2. 진단기에서 에어주입 어댑터 셀프 테스트 기능을 실행합니다.

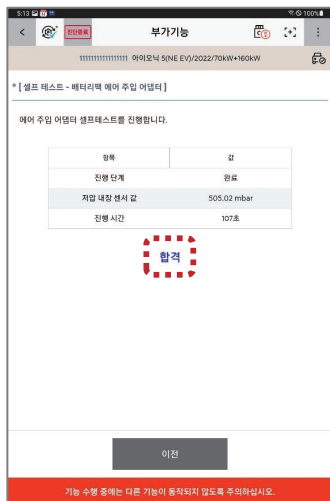

테스트 결과	조치	
PASS (합격)	직전 판정 유지	
FAIL (불합격)	Step 1	에어주입 어댑터 실리콘 오링 교체 (Page 24 참고)
	Step 2	배터리팩 기밀 테스트 재 실행

6. 스페어 파트 교체 방법

6-1. 에어주입 어댑터/압력센서 모듈(배터리팩) 오링 교체 방법



A. 기존 오링 탈거



B. 이물질 제거 (정비용 티슈 사용)

※ 압력센서 모듈은 이물질 제거시
에어건 사용 금지 (압력센서 파손)



C. 신품 오링 체결

6-2. 냉각수 피팅(IN/OUT) 각링 교체 방법



A. 기존 각링 탈거

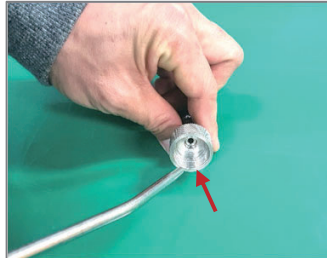

B. 에어컨 세척 (이물질 제거)



C. 신품 각링 체결

6-3. 냉각수 피팅(IN/OUT) R핀 교체 방법

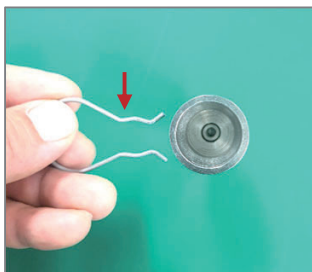

A. 기존 R핀 탈거



B. 신품 R핀 체결

7. 제품 보증 / 제품 인증

7-1. 제품 보증

구분	보증기간
본체	구매일로부터 2년
악세사리	

※ 단, 고객과실 및 부주의로 인한 제품 파손/불량 발생시 유상수리 됩니다.

7-2. 제품 인증



Note : This equipment has been tested and found to comply with the Limits for a Class A digital device, pursuant to part 15 of the FCC Rules. These Limits are designed to provide reasonable protection against harmful Interference when the equipment is operated in a commercial environment. This equipment generates, uses, and can radiate radio frequency energy and , if not installed and used in accordance with the instruction manual, may cause harmful interference to radio communications. Operation of this equipment in a residential area is likely to cause harmful interference in which case the user will be required to correct the interference at his own expense.



인증번호 : R-R-UJA-ULT-M100
RF Module : R-C-csi-BoT-nLE521



사 용 자 안 내 문

이 기기는 업무용 환경에서 사용할 목적으로 적합성평가를 받은 기기로서 가정용 환경에서 사용하는 경우 전파간섭의 우려가 있습니다.

통합 기밀 검사장비

ULT-M100



GIT Co., Ltd

서울 특별시 송파구 마천로 87 지아이티 빌딩

Tel : 02 2189 3300

Email : sales@gitauto.com

Web : www.gitauto.com